

SELECT Dosing System

G5

Instructions for Use

Ref: 16.2 IFU G5 Stenner Mar 08

Contents

Page	
2	Description
2	Installation
4	Changing pump tubes
7	Pump tube life
7	Safety
7	Accuracy
7	Electrical supply
7	Operation
11	Sensor numbers
11	Dosing-screen ratio portrayal
11	Pump tubes, water-line and outputs
12	Calculation of max. water flows for different ratios
12	Selecting low or high pressure tube
12	Dosing with a double pump-head
12	Water meter total
12	Flow sensor capacities
12	Proportional dosing
13	Alarms and warning
13	Water-line pressure
13	Constant pumping (priming)
13	Pumping problems and errors
14	Maintenance
14	Spare parts

Featuring G5 programming
Litres
Multiple Languages

PO Box 103, Saffron Walden, CB11 3GD, UK
Tel/Fax: +44 (0) 1799 551199
e-mail: info@camag.co.uk www.camag.co.uk



Description

The Select G5 dosing system combines the Select dosing control computer software with a well established and rugged motor and pump head to give accurately controlled high pressure dosing.

The Select G5 system is designed to allow the dosing of any liquid product into water lines at a wide range of dosing ratios. The components are: the main control unit, a motor with either one or two pump heads attached to it, a water flow sensor, and connections to the drinking lines. There are no user serviceable parts inside the Select control box or the motor unit.

Warning:

Electrical connections involving 220 – 240V AC should be carried out by competent electricians only

Disconnect from electric supply before opening control box

Beware of pinching fingers in turning rollers when changing tubes

Installation

1

The Select G5 control box and the motor/pump unit are mounted close together and within 2 metres of the stock solution container.

Two separate electrical connections need to be allowed for; - 12V DC 300mA from transformer supplied to power the doser control box, and mains electrical power for the motor/pump unit (240V AC or 110V AC depending on local conditions). Ensure that the motor supplied is correctly specified for your area.

The complete G5 system is supplied as shown with a single pump head with one tube size fitted. See below for tube size options.



2

The motor/pump unit should be mounted vertically with the pump head lowest.





This is one mounting possibility. The rain roof can be used to protect the motor from dirt and moisture.

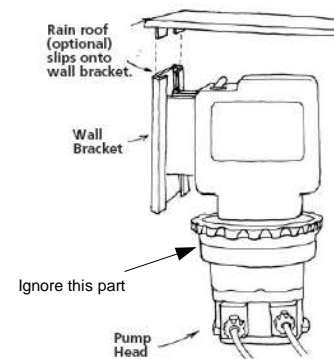

Note: the motor/pump unit is rated for outside use, but the control box is rated for indoor use only.

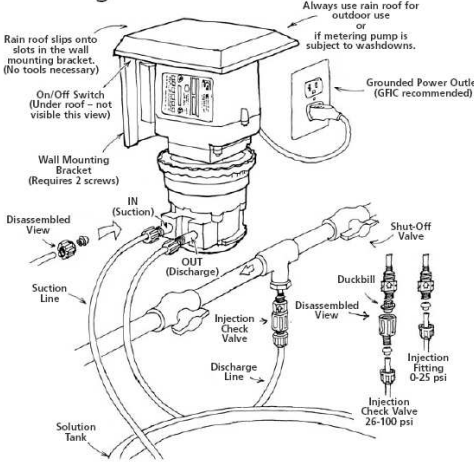
Do not mount the Select G5 system over an open topped stock container as fumes can affect the component parts.

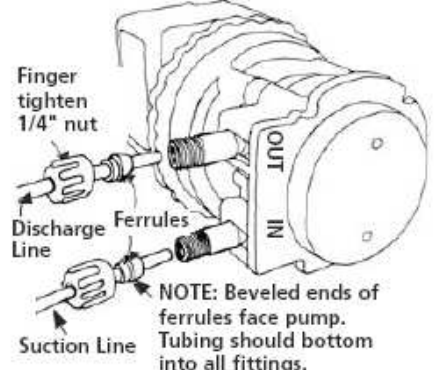
Protect the motor unit from ingress of liquids.

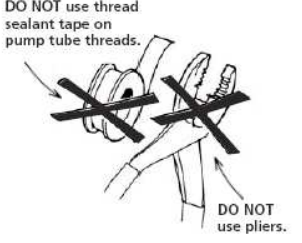

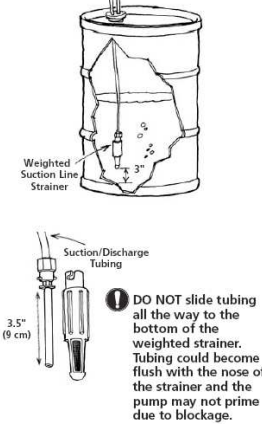
<p>3 This is a generalised layout diagram. Not shown are the Select G5 control box and the flow sensor installation.</p> <p>With this pump system a non-return valve (check valve) containing a “duckbill device” is recommended when using high pressure (up to 6.9 bar) tubes #1, #2 and #7.</p> <p>An RCD device is recommended to be used on the mains electric supply point.</p>	
<p>4 Flow sensor installation.</p> <p>The sensor should be fitted upstream of the injection assembly T piece with water flow in the direction of the arrow on the sensor.</p>	
<p>5 The delivery tube should be cut cleanly to the desired lengths to suit the suction part from the bottom of the stock container to the pump, and from the pump to the injection point.</p> <p>The ferrules are coloured (blue in most countries but clear or white in USA/Canada and Mexico) shaped washers that ensure the seal between the delivery tube and the pump tube end fitting.</p>	
<p>6 The blue ferrule should be pushed 5mm on to the delivery tube as shown. It may be necessary to warm the ferrule to ease fitting.</p>	
<p>7 It is important that the plastic nuts are only tightened by hand otherwise the ferrules will be damaged. Hold the pump tube end fitting with one hand while tightening the nut with the other.</p> <p>Use no PTFE or other sealing tape.</p>	<p>DO NOT use thread sealant tape on pump tube threads.</p>  <p>DO NOT use pliers.</p>

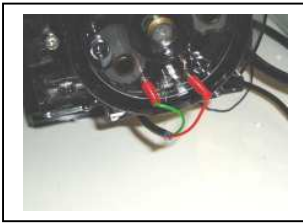
<p>8 The Select G5 System is supplied with an end weight with strainer to fit to the suction tube. If no strainer is required use an alternative end weight (stainless steel nut or similar).</p> <p>Remove the collet from the end weight, push the suction tube 90mm or so through the collet, then re-fix the collet to the weight.</p>	
<p>9 The discharge delivery tube is fitted to the injection assembly in the same way as the delivery tube is fitted to the pump tube ends. Use the plastic nut and ferrule. Tighten by HAND only.</p>	
<p>10 To ensure that pump head damage is kept to a minimum in the event of a fractured tube, fit the tube-burst pins into the two small holes in the pump head cover plate as shown. If a tube should fracture, the dosing operation will be stopped and a warning "Tube Fractured!" will appear on the screen.</p>	
<p>11 Check all connections by re-pressurising the water system and running the motor/pump unit as described below. Tighten / re-fit any connections that show leakage.</p>	

Changing Pump Tubes

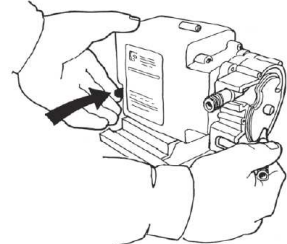
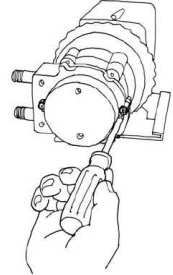
<p>12 Ensure the pump is turned on by using the on/off switch on the rear of the motor (up is on). The motor is turned using the "Load Tube" function on the control system.</p>	
<p>13 Remove the two screws as shown and then remove the pump head cover by lifting the side opposite the tube fittings.</p> <p>Turn the rotor by hand until one of the curved slots is by the suction end of the tube.</p> <p>Set the doser control screen to Load Tube/Yes. At this point the pump rotor will turn 0.3 seconds on, and 1.0 second off. Lift out the suction end of the pump tube and guide the tube out of one of the slot in the roller assembly.</p>	

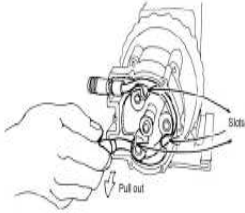
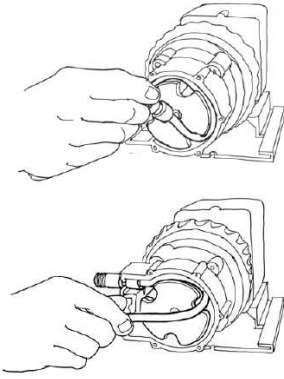
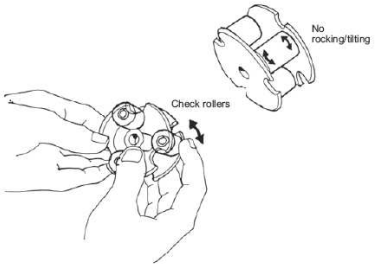
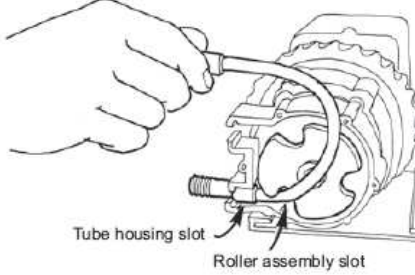
14	<p>Guide the tube completely out of the roller assembly.</p>	
15	<p>When the tube is away from the roller assembly, either turn off the motor on the switch at the back of the , or press “Stop” on-screen.</p> <p>Completely remove the tube assembly.</p>	
16	<p>Remove the roller assembly and housing from the motor shaft. The housing is removed by turning it by 1/8th turn in a clockwise direction and pulling clear. If there is chemical or dirt build-up preventing the housing from being pulled clear, use a flat head screw driver to lever the housing away from the motor AFTER turning by 1/8th turn.</p> <p>Clean all parts (pump head housing, roller assembly and cover) as necessary.</p> <p>Check housing for cracks and replace if cracked.</p> <p>Ensure rollers turn freely. Check rollers for excessive side play from bore wear. Replace roller assembly if worn.</p>	
17	<p>Inspect the suction and discharge tubing, point of injection and non-return valve for blockages. Clean and/or replace as required.</p> <p>Re-install the clean housing and roller assembly.</p>	
18	<p>You will find it easier to fit a new tube if the motor unit is securely fixed to a horizontal surface.</p> <p>Manually turn roller assembly anti-clockwise to line up a slot with the tube housing slot.</p> <p>Place the tube fitting into the housing and roller assembly slot.</p> <p>Use the “Load Tube” function, hold the threaded tube fitting and guide the tube with slight tension towards the centre to prevent pinching between the housing and roller assembly.</p> <p>TAKE CARE NOT TO PINCH YOUR FINGERS.</p>	

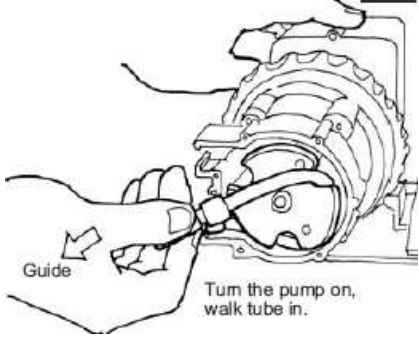
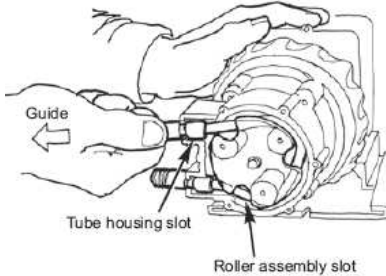
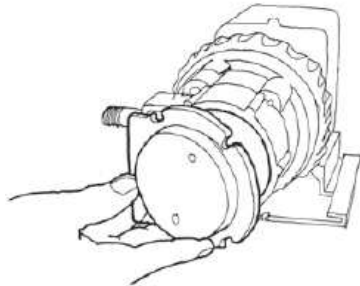
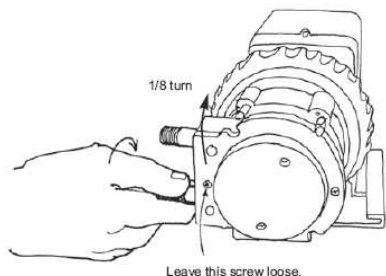
19	<p>When the tube reaches the top housing slot, press Stop.</p>	
20	<p>With the tube end assembly held in the slot, Use the Prime function and allow the rollers to turn and stretch the tube into place.</p> <p>NOTE: Take extra care when fitting Tube #7, as this is the largest high pressure tube and requires some effort to ensure stretching to the correct length. You may find it easier to fit one of the plastic end nuts (supplied) on to the end of the tube assembly to enable greater purchase when guiding the tube end.</p> <p>A used tube will stretch approximately 18mm over its life. The new tube will appear stiff and short, hence the need to allow the rollers to stretch the tube into place.</p> <p>Fit tube end assembly into the slot when able to do so.</p> <p>Turn the motor off.</p>	
21	<p>A small amount of grease (AquaShield®) recommended can be applied to the bush in the pump cover.</p> <p>Replace the cover and screws leaving the screw between the tube fittings loose so that the tube fitting can be rotated to centre the tube on the rollers.</p>	
22	<p>To centre the pump tube on the rollers, ensure that the Select control screen is still showing Priming...</p> <p>Turn the motor on.</p> <p>Turn the IN (suction) tube fitting located on the bottom of the pump head not more than 1/8th of a turn in the direction that the tube must move. Do not let go of the fitting until the tube rides approximately in the centre of the rollers.</p> <p>Turn the motor off. Let go of the fitting and tighten the cover screws.</p>	

23

The cover is not on securely if there is a gap between the screw head and the pump cover.

If a clicking noise is heard when the rollers are turning, the cover is not fully in place. Check and re-tighten the screws as necessary

NOTE: If the screw holes become damaged, it is possible to use 2 other diagonally opposite holes in the pump cover and housing. The screws are self-tapping.

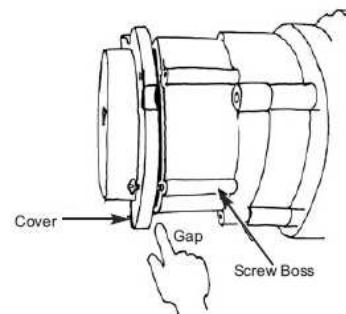

Pump Tube Life

The life of the pump tube will depend on many factors including the product being dosed, the back pressures under which the pump is working, and the amount of time the pump needs to run to perform correctly. The life of the pump tubes is estimated to be up to 1 year, but the tube life could be considerably less depending on operating conditions. Ensure that the tube-burst function is correctly fitted and activated to ensure that the Select G5 system stops immediately that a tube fracture is detected. Periodic inspection and replacement of the pump tube will ensure that tube fractures are avoided.

Safety

The Select doser is an extremely safe unit. However, the following points should be observed:

Normal electrical safety precautions apply. Avoid water contact with any pump parts apart from the pump tube in normal working. Do not immerse the Select G5 doser.

Take precautions to ensure the Select doser can not fall into the stock solution. Consider extra tethering if necessary. Cover stock solution at all times. If immersion does happen accidentally, isolate the Select G5 Doser from the electrical supply immediately.

The use of safety circuit breakers is recommended. If in doubt seek advice from a qualified competent electrician.

Accuracy

The Select doser is factory set to give accurate dosing. If, during normal operation, the output needs to be increased or decreased slightly, this can be achieved via the screen command "Adjust %".

Electrical Supply

The Select G5 doser uses a 12V DC power supply for the control box. This can either be supplied from a 12V battery or via a transformer power supply from the mains electricity supply. A 300mA maximum current power supply is recommended.

The pump motor requires a mains electrical connection of 220-240V AC 50Hz single phase (110V AC 60Hz in USA, Canada and Mexico).

Operation

24

This is the **Welcome Screen**

If this screen is not shown, press and hold the left (Adjust) button for 1 second.

To see the options available press "Set" (Options)
To start dosing immediately, press "Adjust (Start)

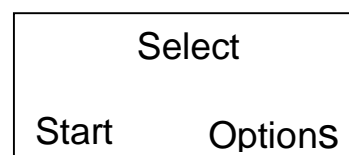

25	<p>If the "Options" button is pressed, the first option is to choose if the doser will continue to dose in a situation when the water flow is out of range (too high). Press Adjust until Y (yes) or N (No) is shown. With Y the doser will run constantly at high water flow. With N the doser will stop dosing and return to the welcome screen at high water flow.</p> <p>Press Set with the correct Y or N shown.</p>	<div style="border: 1px solid black; padding: 10px; text-align: center;"> <p>Doser options</p> <p>Cont at Hi Flo Y</p> </div>
26	<p>Where tube fracture alarm option is fitted, press Adjust to select either Y to enable (activate) the tube burst function, or N to cancel it.</p> <p>The selection must be N if the tube burst system is not fitted.</p> <p>Then press Set.</p>	<div style="border: 1px solid black; padding: 10px; text-align: center;"> <p>Doser options</p> <p>Tube Burst En. Y</p> </div>
27	<p>The third option is the selection of operating language. Press Adjust repeatedly until the desired language is shown. Then press Set to return to the Welcome Screen. All on-screen instructions will now be in the chosen language.</p> <p>At the Welcome Screen press Start</p>	<div style="border: 1px solid black; padding: 10px; text-align: center;"> <p>Doser options</p> <p>Lang. English</p> </div>
28	<p>IF ONLY WATER METERING (NO DOSING) IS DESIRED</p> <p>Press Adjust (Meter)</p> <p>If dosing is required, skip to Step 32.</p>	<div style="border: 1px solid black; padding: 10px; text-align: center;"> <p>Select</p> <p>Meter Dose</p> </div>
29	<p>Press Adjust repeatedly until the correct flow sensor number (the one to be connected to the doser) is shown.</p> <p>See below under Sensor Numbers for a description of sensor.</p> <p>Then press Set.</p>	<div style="border: 1px solid black; padding: 10px; text-align: center;"> <p>Sensor Type?</p> <p>3.1 Sensor3, 1PH</p> </div>
30	<p>The Select doser is also a water meter. If you wish to reduce the water total to zero, press Set. If you wish to keep the water total already recorded, press Adjust.</p> <p>The water total is updated each 5 minutes. Short recording times may lose a small amount of water data.</p>	<div style="border: 1px solid black; padding: 10px; text-align: center;"> <p>Zero water tot?</p> <p>No Yes</p> </div>
31	<p>This is the metering screen. The flow rate of water is 4,740 litres per hour, Sensor 3 with a single pump-head has been selected, and the total on the water meter is 108 litres.</p> <p>Press and hold the Adjust button for a short time to exit this screen.</p> <p>Note: If sensor 5.1 or 5.2 is selected, the flow rate and water total is shown in '00 litres, so 34H is 3,400 l/hr and 456T is 45,600 litres (or US gals as appropriate).</p>	<div style="border: 1px solid black; padding: 10px; text-align: center;"> <p>Meter only 4740H</p> <p>00000108T S3.1</p> </div>

32	<p>TO DOSE PRODUCT USING THE SELECT DOSER</p> <p>Press Set (Dose) to start the dosing selection process.</p>	<div style="border: 1px solid black; padding: 10px; text-align: center;"> <p>Select</p> <p>Meter Dose</p> </div>
33	<p>First choose the flow sensor that is to be connected to the doser (it will be written on a tag attached to the sensor plug). See below under Sensor Numbers for a description of sensor.</p> <p>Then press Set</p>	<div style="border: 1px solid black; padding: 10px; text-align: center;"> <p>Sensor Type</p> <p>3.1 Sensor3, 1PH</p> </div>
34	<p>By pressing Adjust repeatedly the available ratios are shown. When the desired ratio is shown, press Set</p> <p>See Dosing Screen Ratio Portrayal below for explanation of symbols.</p>	<div style="border: 1px solid black; padding: 10px; text-align: center;"> <p>Ratio 1:?</p> <p>100A</p> </div>
35	<p>Ratios of above 1:1000 may be shown as on this screen using K where K is the abbreviation for thousand. 12K5 is 1:12,500, 20K is 1:20,000</p>	<div style="border: 1px solid black; padding: 10px; text-align: center;"> <p>Ratio 1:?</p> <p>12K5A</p> </div>
36	<p>Once the desired ratio has been selected, the correct tube to fit is displayed. Fit the correct pump tube as described in Changing Pump Tube above.</p> <p>Alternatively, if you have a second pump head with the correct tube fitted, clip this pump head onto the motor now.</p>	<div style="border: 1px solid black; padding: 10px; text-align: center;"> <p>1:100A</p> <p>Use tube: #7</p> </div>
37	<p>Pump tubes may be slightly too large or too small after manufacture. The correction for this is shown as % Adjust on the packet that the tube was supplied in. Press Adjust to scroll from -20% to +20% until the correct tube adjust is shown. Then press Set.</p> <p>This feature can also be used to increase or decrease the rate of dosing as required by the dosing operation being performed.</p>	<div style="border: 1px solid black; padding: 10px; text-align: center;"> <p>Adjust %</p> <p>-5%</p> </div>
38	<p>The Select doser is also a water meter. If you wish to reduce the water total to zero, press Set. If you wish to keep the water total already recorded, press Adjust.</p> <p>The water total is updated each 5 minutes. Short recording times may loose a small amount of water data.</p>	<div style="border: 1px solid black; padding: 10px; text-align: center;"> <p>Zero water tot?</p> <p>No Yes</p> </div>
39	<p>If a new / replacement tube is to be fitted or an old tube removed, press Yes to start the rotor turning 0.3 seconds on, and 1.0 seconds off. This facilitates the fitting and removal of tubes.</p>	<div style="border: 1px solid black; padding: 10px; text-align: center;"> <p>Load Tube?</p> <p>No Yes</p> </div>

40	<p>Press stop when the new tube is fitted, or the old tube removed.</p>	<div style="border: 1px solid black; padding: 10px; text-align: center;"> <p>Loading...</p> <p>Stop</p> </div>
41	<p>In order to fill up the delivery tube with the product to be dosed, press Set (Yes). The pump will run constantly to fill the delivery tube. Press No if tube filling is not required.</p> <p>Pump priming can be used to bed-in a new tube.</p>	<div style="border: 1px solid black; padding: 10px; text-align: center;"> <p>Prime pump?</p> <p>No Yes</p> </div>
42	<p>This screen will be shown while the pump is running to fill the delivery tube. Press Stop once the tube is full up to the injection assembly.</p>	<div style="border: 1px solid black; padding: 10px; text-align: center;"> <p>Priming...</p> <p>Stop</p> </div>
43	<p>For the first few seconds, this screen will be shown. The doser is collecting water flow information before dosing commences.</p> <p>Each 20 seconds the pump will run to dose the precise amount of product to suite the water flow and dosing ratio. The normal dosing screen is then shown.</p>	<div style="border: 1px solid black; padding: 10px; text-align: center;"> <p>100A #7 -5 0H</p> <p>Dosing... S3.1</p> </div>
44	<p>This is the normal dosing screen. A ratio of 1:100 has been selected, a high pressure tube #7 has been fitted, the water flow rate is 420 litres per hour, the water meter is showing a total of 106 litres, and Sensor 3 has been chosen using a single pump head.</p>	<div style="border: 1px solid black; padding: 10px; text-align: center;"> <p>100A #7-5 420H</p> <p>00000106T S3.1</p> </div>
45	<p>If the water flow is too high for the doser to be able to dose correctly, this screen is shown each 20 seconds alternating with the normal dosing screen to show the water total. If "Cont at Hi Flo?" is set at Yes, the doser will run continuously, but will return to normal dosing when the water flow reduces to a manageable level. Press Adjust for a short time to return to the Welcome Screen and clear the "High Flow!" message.</p>	<div style="border: 1px solid black; padding: 10px; text-align: center;"> <p>50 Red-5 1420H</p> <p>High Flow! S3.1</p> </div>
46	<p>If Tube Fracture detection kit is fitted, and if liquid from a fractured tube connects the two gold pins, this message will be shown on-screen and the doser will stop dosing.</p> <p>Ensure the tube is replaced and the pump head cleaned and dried before restarting dosing.</p> <p>Press OK to return to the Welcome Screen.</p>	<div style="border: 1px solid black; padding: 10px; text-align: center;"> <p>Tube fractured!</p> <p>OK</p> </div>

To make any adjustments to settings, return to the Welcome Screen and progress through the options. To return to the Welcome Screen, press and hold **Adjust** from the Operational Screen.

Sensor Numbers

Because the pump can be fitted with either one or two pump-heads, the sensor numbers are shown as follows to take account of the different output performance:

Sensor Number	Sensor	Pump-heads	On-Screen definition
2	VTY10	Single	2.1
2	VTY10	Double	2.2
3	VTH25	Single	3.1
3	VTH25	Double	3.2
5	VTH40	Single	5.1
5	VTH40	Double	5.2

It is important to choose the correct on-screen sensor definition to match the number of pump-heads fitted.

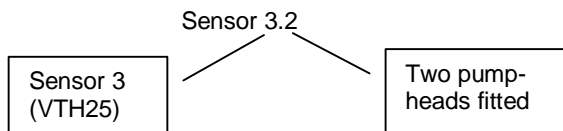

If a single pump-head is fitted you should select Sensor 2.1, 3.1 or 5.1 depending on which flow sensor is being used.

If two pump-heads are fitted to dose the **same** liquid into a water line, you must select Sensor 2.2, 3.2 or 5.2. You would do this in order to increase the output of the doser to dose into larger flows of water.

If two pump-heads are fitted and each will be dosing a **different** product at a **different** dosing ratio, you should select Sensor 2.1, 3.1 or 5.1, and the ratio for the product (Product 1) that the inner pump head will be dosing. The dosing ratio for the product being dosed by the outer pump head (Product 2) will be adjusted by the concentration of the stock solution of Product 2.

Example:

Doser fitted with two pump-heads
 5 bar line pressure
 VTH25 (Sensor 3) fitted
 Product 1 (inner pump-head) to be dosed at 1:1000
 Product 2 (outer pump-head) to be dosed at 1:10,000

Chose sensor 3.1
 Chose ratio 1KA (1:1000 with high pressure)

Product 1 can be dosed neat directly from the original container.
 Product 2 needs to be diluted at a rate of 1 part of product to 10 parts of water

Dosing-Screen Ratio Portrayal

The tube selected and fitted to the doser is abbreviated on-screen as:

On-screen ratio choice	
200A	The ratio is 1:200 using high (All) pressure tubing (1, 2 or 7)
10KL	The ratio is 1:10,000 using low pressure tubing (3, 4 or 5)
33K3A	The ratio is 1:33,300 using high (All) pressure tubing (1, 2 or 7)

Pump Tubes, Water-Line Pressures and Outputs

The pump tubes available for use with the Select G5 system are available in six sizes (different internal diameters). And in a harder and softer style. The harder tubes are smaller in size and can be used with higher water line pressures. The softer tubes are available in both small and large size but can only be used for pressures up to 2 bar. The following chart shows the tubes available:

	Tube Number #	Hard or Soft	Pressure Ability (bar)	Maximum Output at Constant Running
Smaller ↓ Larger	1	Hard	0 – 6.9	0.78
	2 (rarely used)	Hard	0 – 6.9	2.46
	7	Hard	0 – 6.9	5.05
	3 (rarely used)	Soft	0 – 2.0	5.05
	4 (rarely used)	Soft	0 – 2.0	7.57
	5	Soft	0 – 2.0	12.90

Calculation of Maximum Water Flow for Different Ratios

The maximum water flow that can be dosed is:

Max. pump output x ratio = Max water flow

So, if Tube #7 is fitted and the Select G5 system is dosing at a ratio of 1:1000, then the maximum water flow that can be dosed before the doser displays "High Flow" is $5.05 \times 1000 = 5,050$ litres per hour.

If the Select G5 doser is turning for almost the full 20 seconds of each 20 second dosing period, this is the maximum output of the pump. For each pump tube size there will be a maximum water flow that can be dosed based on the maximum output of the pump.

Note: The actual maximum water flow allowable will be the lower value from the chart below or the sensor flow capacity shown above (Flow Sensor Capacities).

Selecting Low or High Pressure Tube

If the water line pressure is above 2 bar, you need to select a dosing ratio with an "A" after the number. E.g. 100A or 1:10KA. Generally the doser will request that a harder smaller bore tube is fitted that can dose into higher pressures. These will be tubes #1, #2 (rarely) or #7.

With water line pressures below 2 bar any tube can be used, but choosing a ratio with an L suffix will lead to a larger bore (larger output), softer tube material tube being requested. This will normally be tube #5 (although tubes #3 and #4 will be asked for rarely).

Dosing with a Double Pump-Head

An extension drive shaft needs to be fitted to the pump before two pump-heads can be used. See separate instructions accompanying the shaft for fitting guidance.

When two pump heads are fitted, the low pressure tubes (#3, #4 and #5) can be fitted to both pump heads.

If the water line pressure is above 2 bar and two pump heads are fitted, only tubes #1 and #2 can be fitted to each pump head. It is not possible to fit two tube #7 to the two pump heads as there is not sufficient motor power. In fact a single pump head fitted with tube #7 gives a greater output than two tube #2.

Note: The rotor assembly is marked with Side A and Side B. Side B will normally have three small silver magnets fitted – these should always be closest to the motor face for the **inner** pump-head. The outer pump-head should ideally have the opposite face (normally A) facing the motor. This helps to lessen strain on the motor, as the rollers will be offset.

Water Meter Total

The maximum quantity of water that is shown on the water total quantity is 100,000,000 litres. After this the meter will return to zero, and water metering will re-commence as normal.

Note: The water meter can be returned to zero during normal dosing by pressing and holding the Set button for 3 seconds. This avoids having to go through the set-up procedure each time the total is returned to zero.

Flow Sensor Capacities

There is a maximum limit on the flow of water permissible through each flow sensor. The maximum flows are:

VTY 10 (Sensor 2)	1,500 l/hr
VTH 25 (Sensor 3)	10,000 l/hr
VTH 40 (Sensor 5)	25,000 l/hr

Proportional Dosing

The full range of ratios possible with the Select G5 doser are achieved by using different size pump tubes. The correct pump tube to use for any specific ratio is detailed on the control screen as described above. The tubes are number coded for ease of recognition. The Number is printed on the side of the tube and in the tube end-fitting.

The dosing ratios in each Select G5 doser are specified by the code number either on the smaller of the two computer chips on the PCB inside the doser, or on the label on the side of the doser. A full list of

ratios for each code number is shown under "Dosing Ratio Data" on www.camag.co.uk or www.dosingsolutions.com.

During proportional dosing, the Select doser constantly monitors the water flow in the drinking line. Each 20 seconds the doser injects exactly the right amount of additive into the drinking line or tank according to the ratio of administration selected. At low water flows it is possible that the doser will not pump every 20 second period. In this case water flow information is stored inside the doser and the pump rotor operated when a minimum dose can be applied.

Complete mixing of additive into the drinking water is achieved by turbulent flow in pipe-work.

Alarms and Warnings

If a high water situation is detected where the doser is unable to keep pace, the doser will either continue to dose and display "High Water" on-screen (If the High Flow Register is set to Continue to Dose), or a warning will be shown on-screen and the doser will stop operation (If the High Flow Register is set to Stop Dosing).

If, for some reason, the rotor becomes jammed or there is a mechanical fault within the pump drive system a warning – "Pump Error" may appear on-screen. If the fault is not immediately apparent and rectifiable, PLEASE CONTACT YOUR DISTRIBUTOR.

Water Line Pressure

The doser will operate against a water pressure in the drinking line of up to 2 bar for tube numbers 3, 4 and 5. (2 bar = 28psi = 66ft H₂O = 20.4m H₂O). Pressures up to 6.9 bar can be dosed with pump tubes 1, 2 and 7. Fit a pressure reduction device if necessary.

Constant Pumping (Priming)

If the priming option is selected from the menu on the control screen (see above) the pump rotor will turn continuously regardless of the flow in the drinking line. This can be useful for filling the suction and delivery lines prior to proportional dosing. It can also be used if a particular product needs to be dosed quickly within a given period. The following pumping rates will be achieved when the Select doser is set to "prime":

Pump Tube Number #	Priming pump rate l/hr One pump head	Priming pump rate l/hr Two pump heads
1	0.78	1.56
2	2.46	4.92
7	5.05	Not possible
3	5.05	10.10
4	7.57	15.14
5	12.90	25.80

It is not recommended to use the Select doser for more than 2 hours at a time in the priming mode, as tube and motor life will be reduced.

Pumping Problems / Errors

If the Select doser fails to operate correctly, check the following: (If the problem can not be resolved – contact your Distributor)

Problem	Solution
Rotor jamming against the pump tube.	This is most likely to happen with Tube #7. Run the pump on Prime for 30 mins. to bed the tube in before dosing.
Error message "High Water" showing on screen.	<ol style="list-style-type: none"> 1. Problem may have passed, check if max. water flow is still being exceeded 2. Consider using more concentrated stock solution at a lower inclusion ratio. 3. Possible pump fault. Contact your Distributor.
Unexpected "Tube Fractured" message	Check if the pump tube is fractured or if there is liquid in the pump head connecting the two gold pins. If the tube fractured system is <u>not</u> in use, the tube fracture en. Option should be N.

Incorrect dosing – dose too low	<ol style="list-style-type: none"> 1. Is the correct tube fitted as shown on-screen? 2. Is water line pressure too high? 3. Is non-return valve blocked? 4. Is injection point blocked? 5. Is inlet filter blocked? 6. Has the doser been running on High Flow and unable to keep up with the water flow? 7. Has water flow periodically been lower than the rating of the sensor (see Flow Sensor Capacities above)? 8. Check inlet tube joints for leaks as air may get sucked in
Incorrect dosing – dose too high	<ol style="list-style-type: none"> 1. Is the doser in the vicinity of High Tension Power cables? If so move the doser as there may be interference. 2. Is the correct tube fitted as shown on-screen?
Medication not being pumped from stock container.	<ol style="list-style-type: none"> 1. Check all tube connections are firmly in place. 2. Check there are no blockages anywhere in the delivery line up to the injection point.
Sudden loss of pumping pressure (with possible return of fluid into stock container)	<ol style="list-style-type: none"> 1 Check if there is any lateral movement in the rotor. See Changing Pump Tube above 2 Check for physical damage to pump head fixing screws. If the pump head is loose, pressure will be lost. 3 Check that non-return valve is fitted in delivery line 4 Check that pump tube is not fractured.
Error message “pump error”	A failure of the motor or data encoder is indicated. Check that connections to circuit board from motor are in place. Consult Distributor.
Proportional dosing does not commence	<ol style="list-style-type: none"> 1. Check flow sensor connected 2. Check there is water flow 3. Check the turbine in the flow sensor is free to turn and not snagged. 4. Is mains electric power supply connected to the pump? 5. Is the on/off switch on the rear of the motor in the “up” (on) position?

Maintenance

Weekly

Flush out filters protecting the flow sensor.
 Flush inlet filter on the suction tube end weight
 Inspect the pump tube for signs of wear.
 Check doser output. Adjust as necessary via the control screen.

Monthly

Replace pump tube if any of the following occur:

- Sharply increased rate of dosing
- Split tube

Each 6 Months

After disconnecting from electric supply, remove cover from Select doser and inspect interior of control box. Ensure no ingress of moisture or other contaminant. In case of difficulty, contact your supplier.

Spare Parts and Accessories

Item		Code
For the G5 doser * = number of pump-heads, ** = tube number eg 360CA1#7-UK is G5 doser with 1 pump-head fitted with #7 tube with UK electrical plug.		
Select G5 doser with UK electric connection	Unit	360CA * # ** - UK
Select G5 doser with European electric connection	Unit	360CA * # ** - EU
Select G5 doser with Australian electric connection	Unit	360CA * # ** - AUS

Select G5 doser with USA electric connection	Unit	360CA * # ** - US
Flow sensor (VTY10)	Unit	160CA03
Flow sensor (VTH25)	Unit	160CA05
Flow sensor (VTH40)	Unit	160CA08
Replacement pump tube #1 (Low output, all pressures)	Unit	380CA#1
Replacement pump tube #2 (Slightly higher output, all pressures)	Unit	380CA#2
Replacement pump tube #5 (Large output, low pressure)	Unit	380CA#5
Replacement pump tube #7 (Large output, all pressures)	Unit	380CA#7
Additional standard pump head with tube #1	Unit	369CA#1
Additional standard pump head with tube #2	Unit	369CA#2
Additional standard pump head with tube #5	Unit	369CA#5
Additional standard pump head with tube #7	Unit	369CA#7
Extension drive shaft	Unit	370CA50
Extension pump head with tube #1 (for double head pumping)	Unit	370CA#1
Extension pump head with tube #2 (for double head pumping)	Unit	370CA#2
Extension pump head with tube #5 (for double head pumping)	Unit	370CA#5
Extension pump head with tube #7 (for double head pumping)	Unit	370CA#7
Ferrules (blue 6mm)	Unit	385CA21
Delivery tube	6m	385CA27
Lock nut for delivery tube	Unit	385CA22
Inlet weight assembly (replacement)	Unit	385CA23
Injection assembly (including duckbill NRV)	Unit	385CA24
Duckbill NRV	Unit	385CA25
Roller assembly (replacement)	Unit	385CA28